

Lab V Series Manual

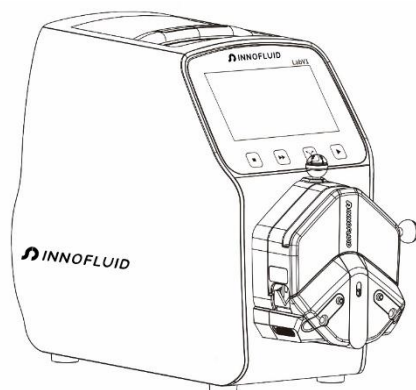



Note:

- Please read the manual carefully before operating the product.



Warning:

- Connect the power cord to the wall socket directly, and avoid using the extended electric wire.
- If the power cord or plug had wear and other damage, please disconnect the plug. (Hold the plug instead of the wire)
- If following situations happened, please turn off the power supply and disconnect the plug. (Hold the plug instead of the wire)
 1. Fluid splash on the pump.
 2. You think the pump need to maintain or repair.
- The user's power socket must have ground wire, and have reliable grounding.

Note: The foot pedal switch and other external control plugs must be connected or disconnected in the power-off status to prevent the external control interface from being burned.

Catalogue

| | |
|-------------------------------------------------|--------|
| 1. Product Introduction | - 1 - |
| 2. Product Appearance | - 1 - |
| 3. Keyboard Instruction | - 2 - |
| 4. Operation Interface Structure | - 3 - |
| 5. Main Functions Operation Process | - 14 - |
| 6. External Control Interface Instruction | - 17 - |
| 7. Technical Specification | - 21 - |
| 8. Functions and Features | - 22 - |
| 9. Dimension Drawing | - 23 - |
| 10. Maintenance | - 27 - |
| 11. Warranty and After-sales Service | - 28 - |

1. Product Introduction

LabV series product are the flow measurement type intelligent peristaltic pump, 4.3 inch color touch screen control; Animation shows working state; flow data, setting parameters and system settings are displayed in the same screen. Intelligent calibration and online micro adjusting function; three measurement modes: fixed volume measurement, dispensing, timer start and stop. It can load different pump heads, multiple external methods are optional. It is the ideal choice for laboratory, equipment supporting and industrial production.

Product mode includes: LabV1, LabV3, LabV6, LabV1-II, LabV3-II, LabV1-III, LabV3-III, LabV6-III

Suitable pump head: EasyPump pump head, AMC pump head (AMC1-AMC12), YZ1515x, YZ2515x pump head, MC series pump head (MC1-MC12), SN series pump head (SN15, SN25), DZ25-3L.

2. Product Appearance

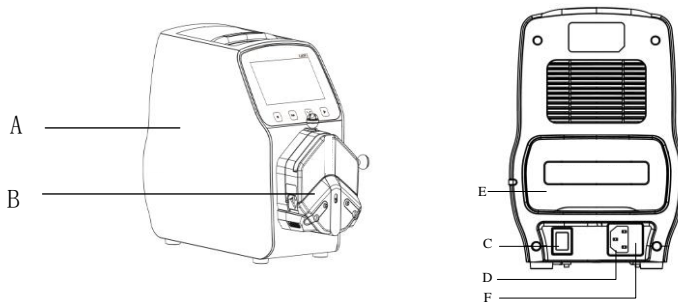

A—Drive

B—Pump Head

C—Power Switch

D—Power Socket

E—External Control Port

F—Built-in fuse

3. Keyboard Instruction

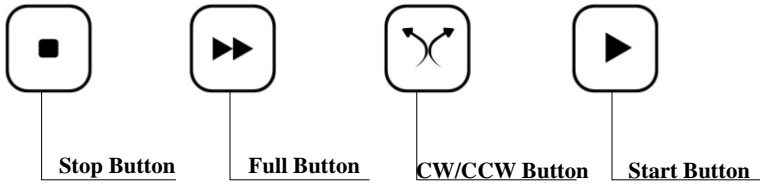

- **Stop Button:** Press stop button, pump stops working. Forbidden buttons in the main interface can be used. Keep pressing the button and turn on the pump power supply, that will initialize the pump and all the parameters will be lost.
- **Full Button:** At stopping state or transferring state, press this button, the pump will run with the highest speed. This button can be used for washing tube or fast filling liquid.
- **CW/CCW Button:** Press this button once, the motor will change running direction once. When the fixed volume measurement or dispensing are on, this button does not work.
- **Start Button:** Press this button, the motor starts running. When fixed volume measurement or dispensing function are on, press this button, the pump will start work with the function. Under the operation of fixed volume measurement, clicking this button again will pause current operation.

4. Operation Interface Structure

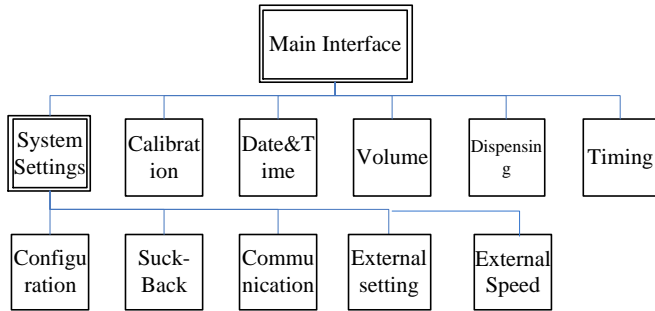

LabV Series Operation Interface Instruction

4.1 Booting Interface

After turn on the system, enter the welcome interface, click anywhere or wait for 2.5 seconds it will enter the English main operation interface automatically.

4.2 Main Interface

Main Interface Composition as below:

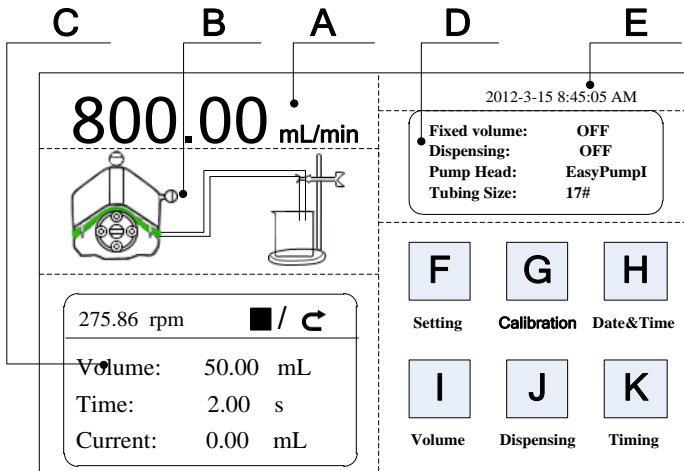

- A. **Speed/Flow Rate Display:** In the flow rate mode, displays the current flow rate, the motor speed is displayed at the C frame. In the speed mode, displays the current set up speed, flow rate is displayed at the C frame. Click A to amend the flow rate or speed. When dispensing function is turned on, A is forbidden, not allowed to amend the flow rate or speed.
- B. **Real-time Dynamic Display:** Real-time display of the current running status, dynamic display of the running results.
- C. **Real-time Parameter Display:** Display the current running state and setting up parameter. When the fixed volume measurement turns on, displays the fixed volume measurement parameter; when the dispensing function turn on, display the dispensing parameter. When these two functions turn off, displaying parameter is all zero.
- D. **Setting Parameter Display:** Display the fixed volume measurement, dispensing state information, the model of pump head and tube size.
- E. **Date and Time Display:** Display the current date and time, you can change it in the system settings. When it displays an alarm clock on the right side, it means the timer start and stop function had turned on.
- F. **System Settings Button:** Click this button, set up other parameters.
- G. **Flow Calibration Button:** Click this button to enter the flow rate calibration interface.
- H. **Date & Time Button:** Click this button to enter set up current date and time interface.
- I. **Fixed Volume Measurement Button:** Click this button, enter the fixed volume measurement interface.
- J. **Dispensing Button:** Click this button, enter dispensing interface.
- K. **Timer Start and Stop Button:** Click this button, enter timer start and stop interface.

4.3 Numeric Keypad Input Interface

Numeric keypad input interface as below:

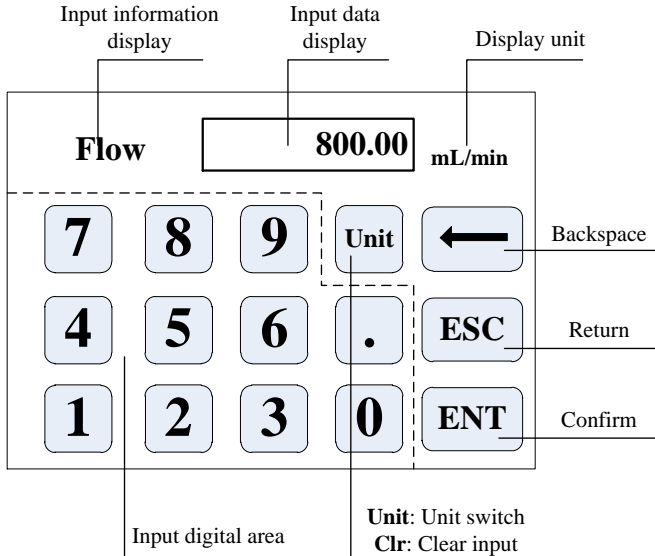

Input Information Display: The information displayed is the current operation object.

Input Data Display: Display the current input data, range is 0.01-9999.

Unit Display: Display input units when input flow rate or volume.

Input Digital Area: Numeric keypad.

Unit/Clr Button: When input flow rate or volume, this button is unit switch, you can choose different units. When it is Clr, you can clear the current input data.

Backspace Button: Delete an input digital.

ESC Button: Cancel the current input, back to previous interface.

ENT Button: Confirm the current input.

4.4 The Basic Configuration Interface

The basic configuration interface:

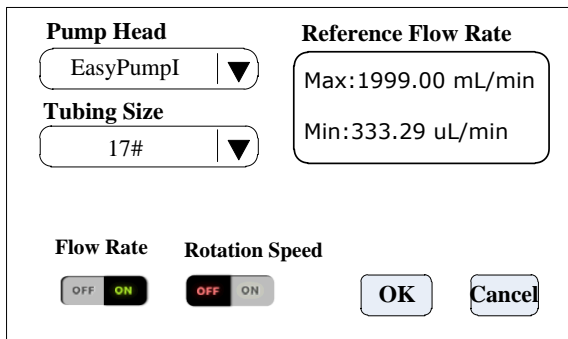

The configuration interface is enclosed in a rectangular box. At the top left, there is a dropdown menu for 'Pump Head' with 'EasyPumpI' selected. Below it is another dropdown menu for 'Tubing Size' with '17#' selected. To the right of these is a rounded rectangular box labeled 'Reference Flow Rate' containing 'Max: 1999.00 mL/min' and 'Min: 333.29 uL/min'. At the bottom left, there are two toggle switches: 'Flow Rate' (set to 'ON') and 'Rotation Speed' (set to 'OFF'). At the bottom right are two buttons: 'OK' and 'Cancel'.

Click the **Pump Head** and **Tubing Size** to choose the pump head and tubing.

Reference flow rate displays the maximum and minimum flow rate with the current pump head and tubing.

Click the Flow rate mode or Speed mode button to choose the working mode. When you choose the flow rate mode, the flow rate is adjustable, the speed will change with the flow rate. When you choose the speed mode, the speed is adjustable, the flow rate will change with the rotating speed.

Click the confirm button when you had finished choosing parameter then back to the main interface.

Note that: When the pump come with two pump heads, the output of two pump heads are connected to one channel with Y type connector, then you will need to choose 2* pump head model; if the two pump heads use as two channels, then you need to choose single pump head model number.

For example, the pump come with two EasyPumpI, and output connect with Y type connector to one channel, then when choose pump head need to select 2*EasyPumpI, as in below picture:

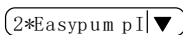

A dropdown menu showing '2*EasyPumpI' selected with a downward arrow on the right.

In other cases, such as: the pump come with one pump head EasyPumpI, or with two

EasypumpI use as two channels, or with 3 or 4 EasypumpI pump heads, need to select single pump head EasypumpI, as in below picture:

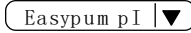

4.5 Back Suction Angle Interface

The back suction angle interface as below:

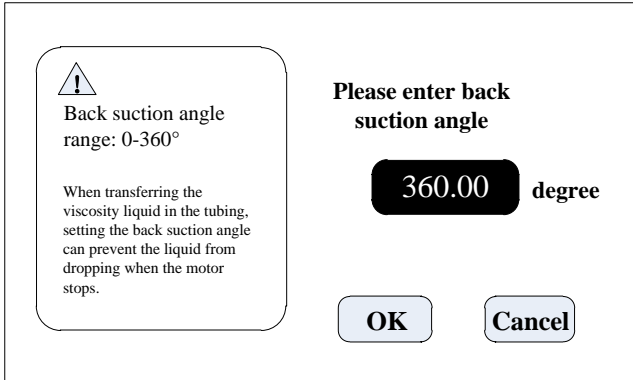

Click the **System Settings** button in the main interface, then click **Back Suction** button to enter the back suction angle setting interface. Click **angle** button, pop up the numeric keyboard for input the suction angle, enter back suction angle then click OK. If click the **Cancel** button, it will back to the system settings main interface.

4.6 External Setting Interface

External Setting Interface as below:

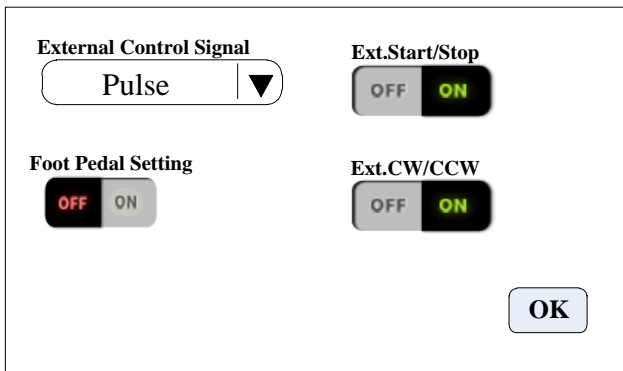

Click **System Settings** button in the main interface, then click **External control** to enter **External Settings** interface.

- a. **There are two types of signals for external control motor start/stop and direction: Level mode and Pulse mode.** Connection interface refer to the external control interface instruction.
- b. **Various external control modes are independently set on switches, which will only work after the corresponding external control function is turned on.**

4.7 External Speed Control Setting Interface

External Speed Control Setting Interface as below:

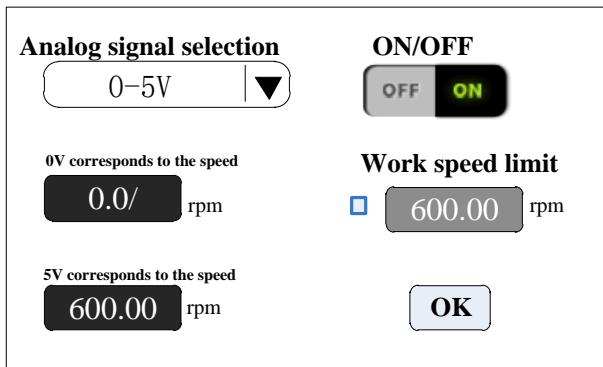

Click **System Settings** button in the main interface, then click **External Speed Control** button to enter External Speed Control Settings interface.

According with external input signal to set the analog signal: **0-5V, 0-10V or 4-20mA**. Between analog signal voltage range and motor speed, there is linear relationship.(when the working speed limit is off).

After turn on the maximum working speed limit, the motor speed will be limited. For example, if 0V to 0rpm, 5V to 600rpm (then 2.5V should be 300rpm). But if the maximum working speed limit is 300rpm, when external input analog signal is 2.5V, the motor speed is 300rpm. After the input signal exceeds 2.5V, the

motor speed remains unchanged at 300 rpm.

4.8 Communication Setting Interface

| | |
|-------------------------------------------|---------------------------------------------|
| Set baud rate 9600 ▼ | Communication protocol Shenchen ▼ |
| Communication interface RS485 ▼ | ON/OFF OFF ON |
| Slave No. 01 | OK |

Click **System Settings** button in the main interface, then click **Communication** button to enter Communication Settings interface.

This pump support Modbus--RTU Mode. Please select baud rates and communication interface (RS485/RS232). Click **Slave No.** button to enter peristaltic pump address No.(range:1-32), select communication enable is **ON**. Then this pump can be communication with master, receiving master signal.

Note: After settings, the peristaltic pump only receives communication control when in the main interface, it is invalid for the communication control in the other settings interface.

4.9 Flow Rate Calibration Interface

Flow Rate Calibration Interface as below:

| | | |
|---------------------------|--------------------------------|-----------------------------------|
| Dispensing | Actual Vol. 0.0000ml | Volume adjust +0.0000ml |
| Volume 10.00 ml | Test | Add |
| Run Time 1.00 s | CAL | Dec |
| | Reset | Esc |

The top left corner displays the function, when fixed volume measurement turn on, displays fixed volume; When dispensing turned on, displays dispensing. Others displays transferring mode.

If dispensing turned on, the target volume and running time are set up parameter, unable to amend. Other modes, the running time is 60s, you can click the run time button to amend the running time.

Before the pump works, need to calibrate the flow rate to ensure the transferring or dispensing accuracy

Process as below:

- (1) Confirm the running time, if dispensing function, the running time is set up time, unable to change.
- (2) Click **Test** button to start the test, countdown displays the run time, it will stop automatically, and display numerical keyboard, input the actual volume, then it will ask whether continue test (suggest more than 3 times), choose **Yes**, the pump will test again, choose **No**, back to the calibration interface.
- (3) After click the **Test** button, during the pump running, you can click the **Stop** button to stop the test.
- (4) After finish the tests, the actual volume area display the average data, click the **CAL** button, prompt the calibration is successful.
- (5) If request higher accuracy, you can click **Add** and **Dec** button to micro adjust the flow rate, to reach high accuracy transferring and dispensing.
- (6) Click **Reset** button, restore to the factory default calibration parameters.

Online Micro Adjust Volume Process:

Flow Rate Transferring Mode: If the actual flow rate during the production process is bigger or smaller than the set up flow rate, you can micro adjust the flow rate online without affecting the product line.

Fixed Time and Volume Mode: If the dispensing volume is bigger or smaller than the set up volume, you can micro adjust the volume online, no need to stop the

pump.

Fixed Volume Measurement Mode: Do not support online micro adjust function.

- Click the **Calibration** button from the main interface, enter the flow rate calibration interface.
- Now only the Add, Dec and Esc button are usable, other buttons are forbidden.
- Click Add or Dec button to micro adjust the flow rate or volume.

4.10 Date & Time Interface

Setting Date & Time Interface as below:

| | | |
|-----------------------------------------|----------------|-------------------------------------|
| <input checked="" type="checkbox"/> | 12-hour | 2012-3-15 |
| <input type="checkbox"/> | 24-hour | 8:45:35 AM |
| <input type="button" value="Set Date"/> | | Thursday |
| <input type="button" value="Set Time"/> | | <input type="button" value="Back"/> |

In that interface, you can set the current date and time, it will display at the top right corner. Click **Set Date** button, come out the **Set year** numeric keypad, the range of the year is **1970-2099**. After set up the year, then set the month and date.

Click **Set Time** button, come out the numeric keypad, set the hour, minute and second.

4.11 Fixed Volume Measurement Interface

Fixed Volume Measurement Interface as below:

| | |
|----------------------------------------------------------------------------------------------------------------------------------------|------------------|
| Fixed volume | Volume |
| <input type="checkbox"/> OFF <input checked="" type="checkbox"/> ON | 600.00 mL |
| <p>Fixed volume function turned on, the current flow rate is 800.00mL/min It needs 0.75 minute to reach to the setting volume.</p> | |
| <input type="button" value="OK"/> | |

After turn on this function, the peristaltic pump will measure the volume automatically, when set up volume finished, the pump will stop working automatically. The flow rate can be changed during the pump working.

Click the **Fixed Volume** button, set **ON** to turn on this function. Click **Set Volume**, to input volume, the unit can be mL or L, range is 0.01mL to 9999L. The prompting frame display the needed time to finish the volume with set up flow rate. The maximum time is 9999min, when more than 9999min, the system will warn.

4.12 Dispensing Interface

Dispensing Interface as below:

| | | |
|-------------------------------------------------------------------------------------|---------------------|-----------------------------------|
| Dispensing | Runing time | Repeat times |
| <input type="checkbox"/> OFF <input checked="" type="checkbox"/> ON | 1.00 s | 0002 |
| Set volume | Suspend time | <input type="button" value="OK"/> |
| 5.00 mL | 1.00 s | |
| <p>Dispensing function turned on, flow rate is 300.00mL/min, speed is 103.44rpm</p> | | |

After turn on this function, the pump will enter dispensing mode.

Peristaltic pump transfer fixed volume in fixed time, transfer times are the **Repeat times**, click suspend time button then input suspend time, prompt box display current diameter, after click the OK button, click the start button, the pump begin dispensing according to the diameter.

4.13 Timer Start and Stop Interface

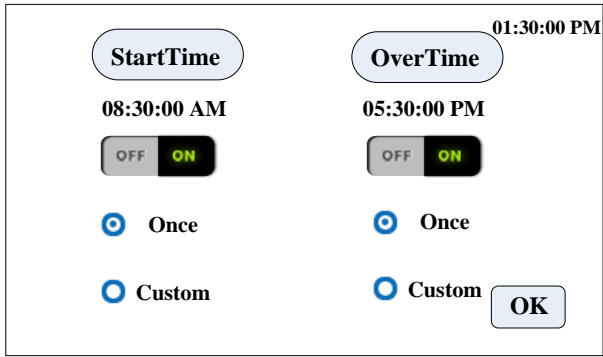

The interface displays two time settings: **StartTime** (08:30:00 AM) and **OverTime** (05:30:00 PM). Each setting has a toggle switch (OFF/ON) and radio buttons for **Once** and **Custom** options. A current time of 01:30:00 PM is shown at the top right. An **OK** button is present at the bottom right.

Start pump and stop time can be set in any time on this function. After the current time reaches to the setting time, it will automatically execute start/stop function or stop the motor.

When the Fixed volume measurement or fixed time and volume function is turned on, the timer stop function is unavailable.

5. Main Functions Operation Process

5.1 Flow Rate Transferring Function

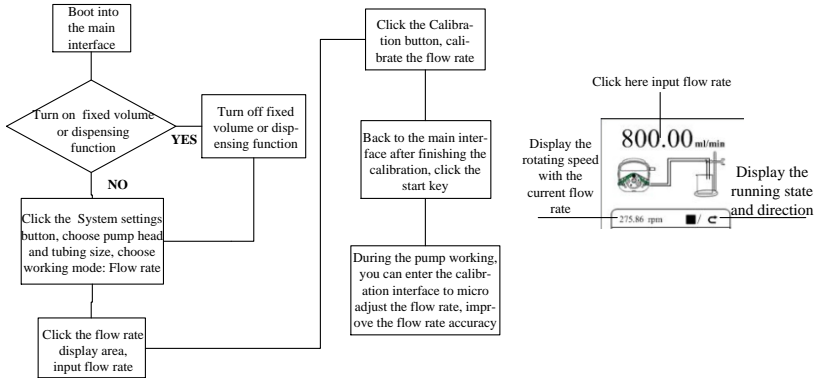

Note: Please refer the flow rate calibration interface instruction for flow rate calibration process.

5.2 Fixed Volume Measurement Function

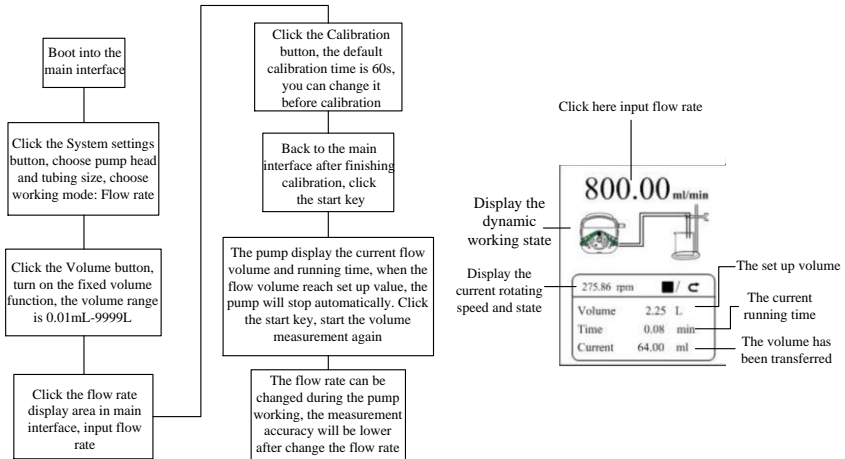

Note: Please refer the flow rate calibration interface instruction for flow rate calibration process.

5.3 Dispensing

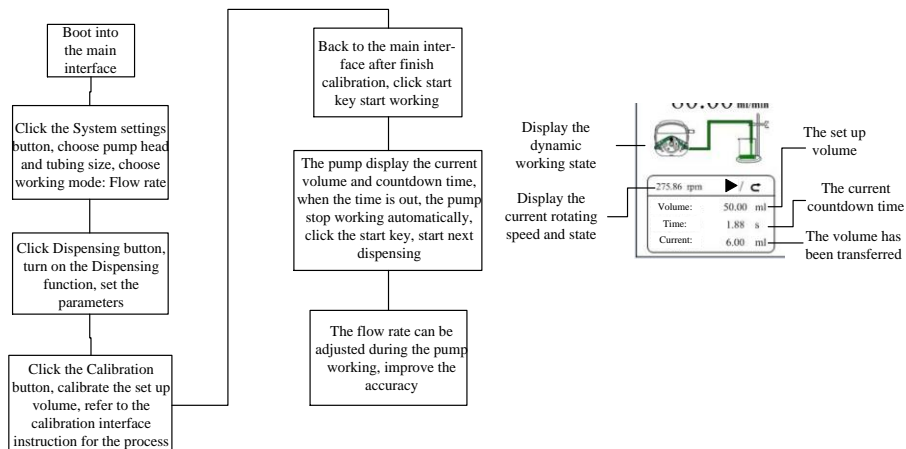

Note: Please refer the flow rate calibration interface instruction for flow rate calibration process.

5.4 Timer Start And Stop Function

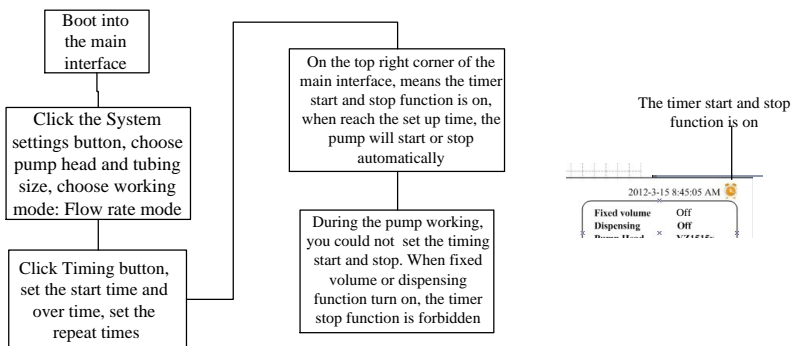

Under the flow rate transferring mode, set the pump start at 8:30 a.m. from Monday to Friday, stop at 5:30 p.m., the process as below:

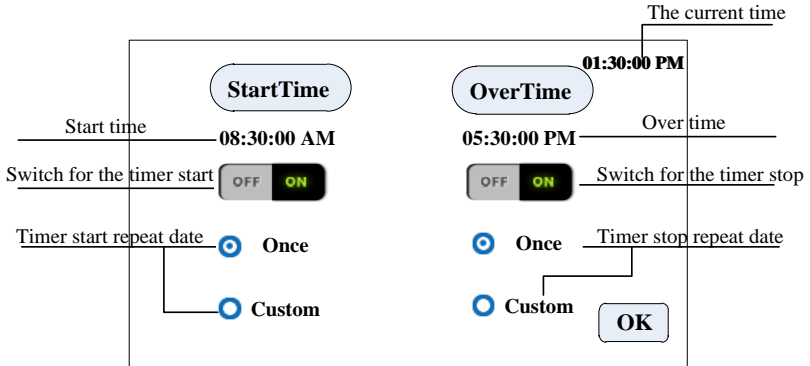

Click **Start Time**, set the start time is 8:30 a.m., turn the button to **ON**.

Click **Custom**, come out the repeat date window, as below:

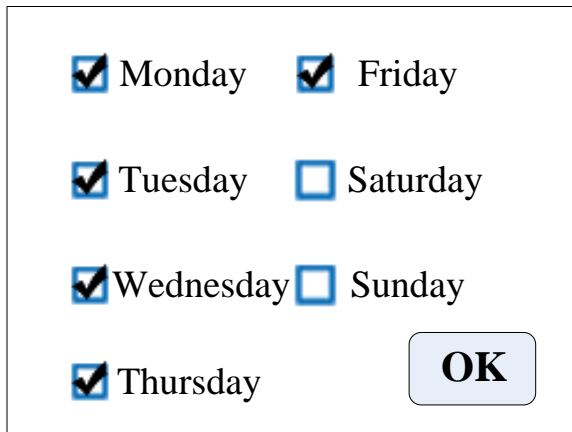

6. External Control Interface Instruction

External control interface as below:

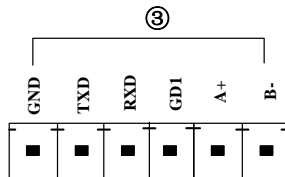
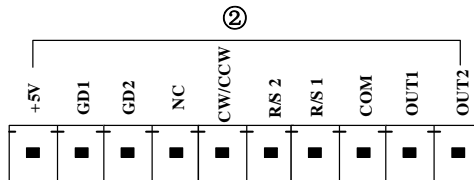
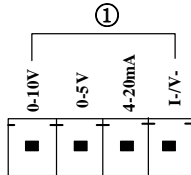
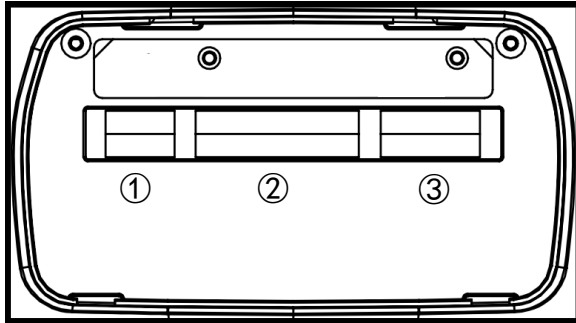

① **Analog signal input terminal:** Choose the External speed control signal and turn on the Ext. Speed in external control setting interface, control the motor speed from 0 rpm to maximum speed through analog signal.

0-10V: 0V to 10V voltage signal input terminal.

0-5V: 0V to 5V voltage signal input terminal.

4-20mA: 4mA to 20mA current signal input terminal.

I_/V_: Analog signal negative terminal.

Notice: Please do not connect 0-10V signal to 0-5V terminal or 4-20mA input terminal. This is forbidden. Wrong connection may damage the pump.

② **External control signal input terminal** (the interface of handing dispenser and foot pedal provided by our company)

a. Internal isolation 5VDC output

+5V: Internal 5V output positive

GD1: Internal 5V output negative

b. External control start/stop, cw/ccw signal input terminal:
Active signal input, 5-24 VDC input.

GD2: External control signal common input terminal.

NC: External control full speed signal input.

CW/CCW: External direction signal input

R/S 2: External start/stop signal input

Set up the external control mode in the setting interface, turn on the correspond external control function, external control signal is active, external control full speed function is enabled by default.

c. External control start/stop signal input port: Passive signal input

R/S 1: External control start/stop signal

The passive switch or foot pedal switch can be connected with the terminal. Set the validity of this input in external setting interface--foot pedal option.

The external control wiring diagram is as follows:

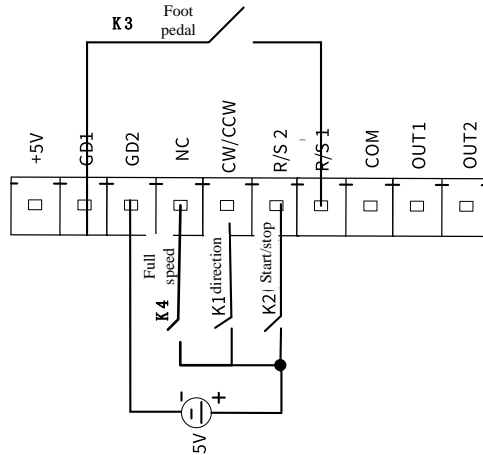

- a. In **Pulse mode**: Short circuited K2 then disconnect, the motor starts running. Short circuited and disconnect again, motor stops running. (Under transferring and dispensing modes, current working has been stopped. Under fixed volume measurement mode, current working has been paused. Disconnect after short circuit again, it will continue to work); In **Level mode**: Short circuited K2, the motor starts running, disconnect K2, motor stops running.
- b. In **Pulse mode**: Short circuited and then disconnect K1 once, the motor changes working direction once. In **Level mode**: Short circuited K1, motor runs in clockwise, disconnect K1, motor runs anticlockwise.
- c. In **Pulse mode**: Short circuited K3 then disconnect, the motor starts running; short circuited K3 and disconnect again, motor stops running. (Under transferring and dispensing modes, current working has been stopped. Under fixed volume measurement mode, current working has been paused. Disconnect after short circuit again, it will continue to work); In **Level mode**: short circuited K3, motor starts running, disconnect K3, motor stops running.
- d. In **Pulse mode**: Short circuited K4, the motor will run with full speed; Disconnect it, the motor stops.

The motor working status output terminal:

Output motor working status as below:

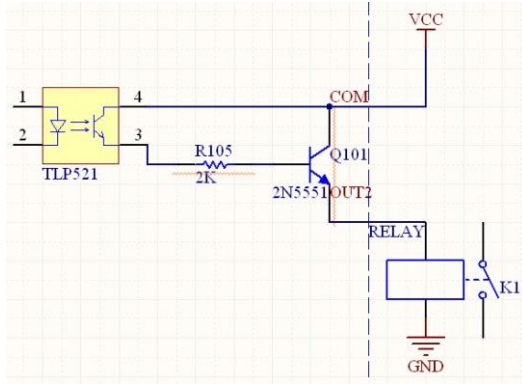

If connect with relays, when the motor runs, K1 connect; when the motor stops running, the K1 disconnect.

③ Communication interface

RS232 communication interface: Choose RS232 in the Communication setting interface, this terminal is active.

GND: Communication ground terminal.

TXD: Master sending, peristaltic pump receive signal terminal.

RXD: Peristaltic pump sending, master receive signal terminal.

RS232 Communication Interface Connection Diagram as below:

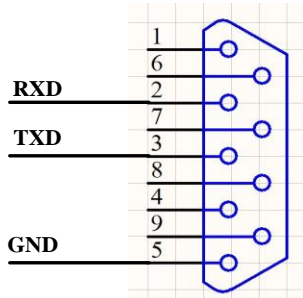

RS485 Communication Interface: Choose RS485 in the communication setting interface, this terminal is active.

GD1: RS485 signal ground

A+: Connect RS485 A+ terminal

B-: Connect RS485 B- terminal

Note: No matter choose RS232 or RS485, the communication protocol is standard MODBUS protocol.

It should be noted that: when leaving the factory, the external control interface will be plugged with terminals. If you need to use other external control equipment of our company, such as foot pedal, hand-held dispensers, etc., please unplug the terminals first, and then plug the external control equipment.

7. Technical Specification

| | | | |
|------------------------|----------------------------------------|------------------|-----------------------------------------------------------------------------------------|
| Flow rate resolution | 0.01ml/min | Power supply | AC 220V±10% 50Hz/60Hz(standard) AC 110V±10% 50Hz/60Hz(optional) |
| Operation mode | Touch screen and mechanical keypad | External control | Switch signal |
| External speed control | 0-5V, 0-10V, 4-20mA for option | External control | Passive switching signal: Foot pedal switch Active switching signal: 5-24V universal |
| Communication | RS232/RS485, support Modbus (RTU mode) | Output port | Output motor running status(Open collector output) |
| Back suction | 0-360° | Protection | IP31 |

| angle | | | rate | |
|-------------------|-----------------------------------------------|----------|----------------------------|--|
| Speed range | LabV1, LabV1-II, LabV1-III | | 0.1-150rpm | |
| | LabV3, LabV3-II, LabV3-III | | 0.1-350rpm | |
| | LabV6, LabV6-III | | 0.1-600rpm | |
| Power consumption | LabV1, LabV1-II, LabV3, LabV3-II, LabV6 | | <50W | |
| | LabV1-III, LabV3-III, LabV6-III | | <80W | |
| Motor type | LabV1, LabV1-II, LabV3, LabV3-II, LabV6 | | Stepper motor | |
| | LabV1-III, LabV3-III, LabV6-III | | Closed loop stepping motor | |
| Temperature | 0-40°C | Humidity | <80% | |

8. Functions and Features

- 4.3 inch color touch screen control, animation shows working state, the flow volume and motor speed are displayed in the same screen.
- Intelligent calibration function, it can calibrate the flow rate and dispensing volume, ensure the flow accuracy, suitable for high accuracy transferring liquid.
- On-line micro adjusting function, it can adjust the flow rate during production progress, to avoid the filling errors because of tubing fatigue and elasticity decreased.
- Accurate angle control technology, reach high precision dispensing and

measurement.

- Fixed volume measurement function: After turn on this function, the peristaltic pump will measure the liquid volume automatically, it will stop automatically after the volume reaches the set value. During this process, the flow rate can be changed. It is suitable for liquid metering in the laboratory or quantitative feeding in the chemical reaction process, etc.
- Fixed time and volume function: After turn on this function, the peristaltic pump will transfer fixed volume within set time. It is suitable for liquid dispensing in laboratory and industrial production.
- Timer start and stop function: Pump starts and stops time can be set any time to realize automation control.
- Power down memory function, store the running parameters in time, safe and reliable.
- Fast fluid-filled function, can wash the tubing and also fill fluid in the tubing.
- High torque and low power loss, it can load several pump heads or multichannel pump head, meet different application requests.
- External control start and stop, convenient for equipment supporting.

9. Dimension Drawing

Unit: (mm)

9.1 Single pump head

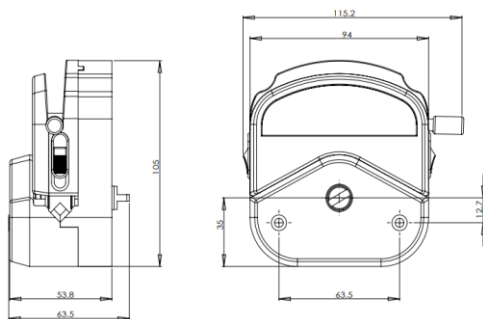

YZ1515x pump head

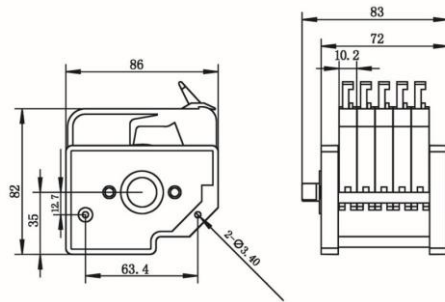

MC5 pump head

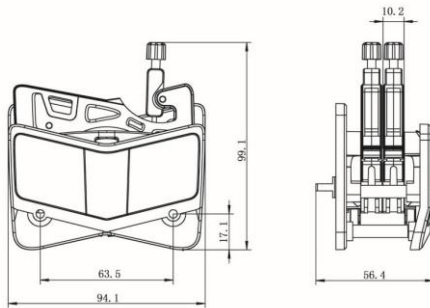

AMC2 pump head

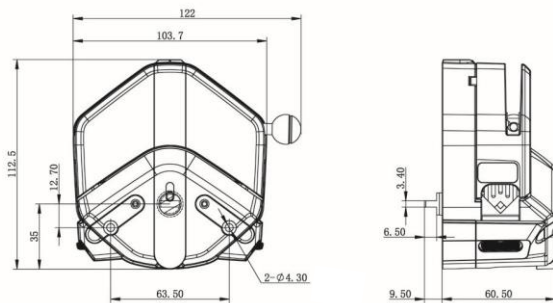

EasyPump pump head

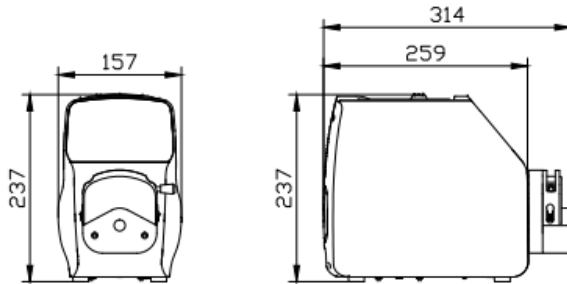
9.2 LabV series product

LabV+YZ1515X/2515X pump head

Note: For each additional pump head in series, the longitudinal dimension shall be increased by 55mm.

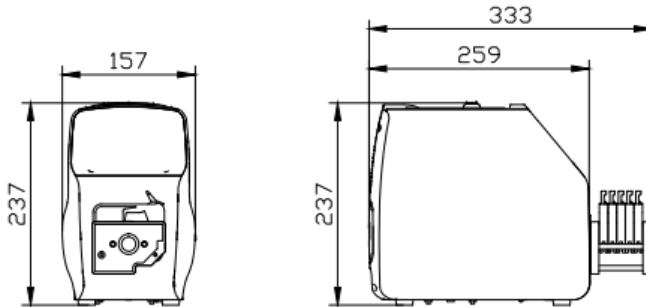

LabV + MC5 pump head

Note: For each additional channel, the longitudinal dimension shall be increased by 10mm.

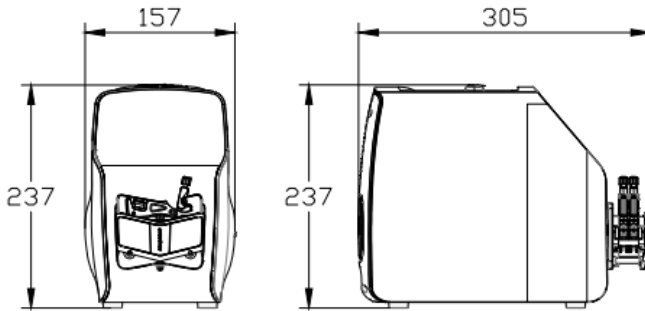

LabV + AMC2 pump head

Note:For each additional channel, the longitudinal dimension shall be increased by 10mm.

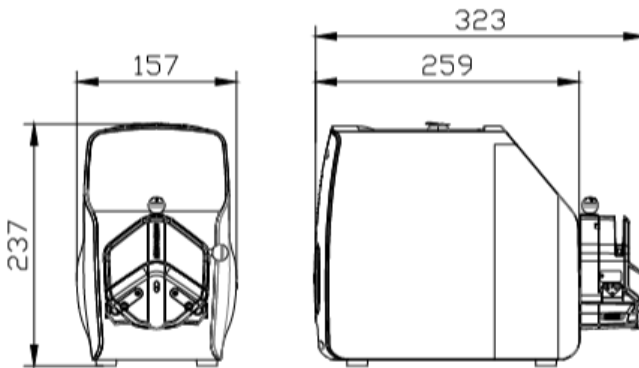

LabV+EasyPump pump head

Note:For each additional pump head in series, the longitudinal dimension shall be increased by 61mm.

10. Maintenance

- Check the running status of machine before starting it, normal operation can be put into use.
- Check for leakage, and correct fault which can be appeared.
- Clean liquid overflowed from the pump in time.
- Please turn off the power supply and unplug the power socket (Hold the socket instead of power cord) when liquid splashed on pump. Check whether liquid flows into the machine, if it does, please contact the manufacture.
- The foot pedal switch and other external control plugs must be connected or disconnected in the power-off status to prevent the external control interface from being burned.
- The user's power socket must have ground wire, and have reliable grounding.
- This product has no waterproof measures. Please take protective measures when using in water environment.
- This product does not have special certification such as medical certification. When it needs to be used in special fields such as medical and military, please self-certify.
- If the pump does not use for a long time, please clean it and keep it in dry and ventilated environment.
- The company shall not bear the direct and indirect losses caused by the malfunction or improper operation of this product.

11. Warranty and After-sales Service

We support 3 years warranty for the pumps, subject to the exceptions below. Our company shall not be liable for any loss, damage, or expense directly or indirectly related to or arising out of the improper use of its products. This warranty does not obligate our company to bear any costs of removal, installation, transportation, or other charges which may arise in connection with a warranty claim.

If the pump fails during the warranty period, after confirmation by our technical department, we will provide spare parts free of charge. Customers will need to bear the shipping cost.

Exceptions:

- The warranty shall not apply to repairs or service necessitated by normal wear and tear or for lack of reasonable and proper maintenance.
- All tubing and pumping accessories as consumable items are excluded.
- Electrical surge as a cause of failure is excluded.
- Chemical attack is excluded.
- Improper operation or man-made damage as a cause of failure is excluded.

Innofluid Co., Ltd.

Add: Building 10, No. 860, Xinyang Road, Lingang New Area, Pilot Free Trade Zone, Shanghai, China.

Manufacturer: Baoding Shenchen Precision Pump Co., Ltd.

Tel: 0086-312-5958380

Fax: 0086-312-6780636

Website: www.innofluid.com

Email: info@innofluid.com

MADE IN CHINA